

SONY CXK5816PN/M 10/10L/12/12L/15/15L

2K-word × 8 bit High Speed CMOS Static RAM

Description

The CXK5816PN/M is a 16,384 bits high speed CMOS static RAM organized as 2,048 words by 8 bits and operates from a single 5V supply. The CXK5816PN/M is suitable for use in high speed and low power applications in which battery back up for nonvolatility is required.

Features

- Low power standby: 5 μ W(Typ.)—L-version
100 μ W(Typ.)—Standard version
- Low power operation: 125mW(Typ.)
- Fast access time: 100ns/120ns/150ns (Max.)
- Single +5V supply
- Fully static memory No clock or timing strobe required
- Equal access and cycle time
- Common data input and output: 3-state output
- Directly TTL compatible: All inputs and outputs
- Low voltage data retention: 2.0V (Min.)
- Pin compatible with MB8416A, HM6116, μ PD446

Structure

Silicon gate CMOS IC

Function

2048-word × 8 bit static RAM

Block Diagram

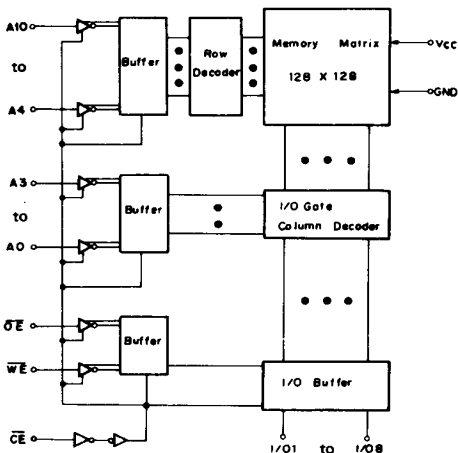

Note) All Typical values are measured under the conditions
Vcc=5.0V and Ta=25°C.

Package Outline

Unit: mm

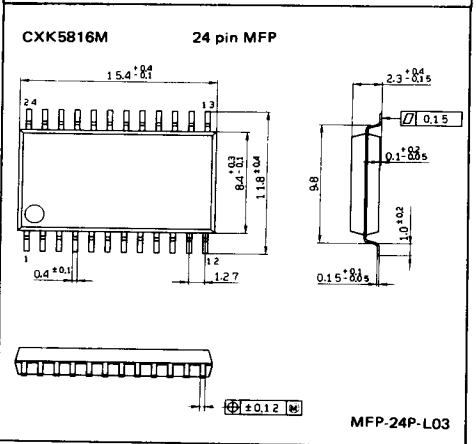
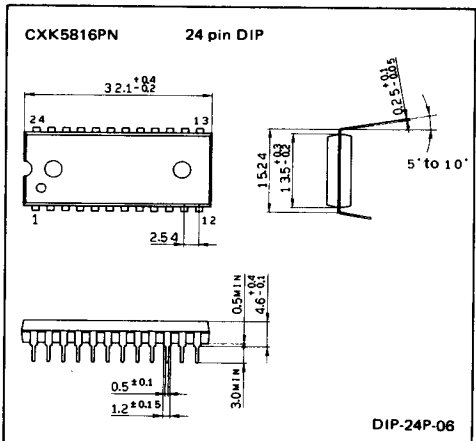

Pin Configuration (Top View)

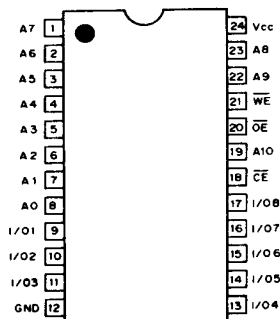

Symbol	Description
A0 to A10	Address Input
I/O1 to I/O8	Data Input Output
\overline{CE}	Chip Enable Input
\overline{WE}	Write Enable Input
\overline{OE}	Output Enable Input
V_{CC}	Power Supply
GND	Ground

Absolute Maximum Ratings

($T_a = 25^\circ\text{C}$, GND = 0V)

Item	Symbol	Rating	Unit
Supply Voltage	V_{CC}	-0.5 to +7.0	V
Input Voltage	V_{IN}	-0.5 to $V_{CC}+0.5$	V
Input and Output Voltage	$V_{I/O}$	-0.5 to $V_{CC}+0.5$	V
Allowable Power Dissipation	P_d	CXK5816PN	1.0
		CXK5816M	0.7
Operating Temperature	T_{opr}	0 to +70	$^\circ\text{C}$
Storage Temperature	T_{stg}	-55 to +150	$^\circ\text{C}$
Soldering Temperature	T_{solder}	260 \cdot 10	$^\circ\text{C} \cdot \text{sec}$

Truth Table

\overline{CE}	\overline{OE}	\overline{WE}	Mode	I/O1 to I/O8	V_{CC} Current
H	X	X	Not Selected	High Z	I_{SB1} , I_{SB2}
L	H	H	Output Disable	High Z	I_{CC1} , I_{CC2}
L	L	H	Read	D out	I_{CC1} , I_{CC2}
L	X	L	Write	D in	I_{CC1} , I_{CC2}

Note) X: "H" or "L"

DC Recommended Operating Conditions

($T_a = 0$ to $+70^\circ\text{C}$, GND = 0V)

Item	Symbol	Min.	Typ.	Max.	Unit
Supply Voltage	V_{CC}	4.5	5.0	5.5	V
Input High Voltage	V_{IH}	2.2	—	$V_{CC}+0.3$	V
Input Low Voltage	V_{IL}	-0.3	—	0.8	V

DC and Operating Characteristics

(V_{CC}=5V±10%, GND=0V, Ta=0 to +70°C)

Item	Symbol	Test condition	CXK5816PN/M -10/12/15			CXK5816PN/M -10L/12L/15L			Unit
			Min.	Typ.	Max.	Min.	Typ.	Max.	
Input Leakage Current	I _{LI}	V _{IN} =GND to V _{CC}	-2	—	2	-2	—	2	μA
Output Leakage Current	I _{LO}	$\overline{CE} = V_{IH}$ or $\overline{OE} = V_{IH}$ V _{I/O} =GND to V _{CC}	-2	—	2	-2	—	2	μA
Operating Power Supply Current	I _{CC1}	$\overline{CE} = V_{IL}$, I _{OUT} = 0mA	—	—	60	—	—	60	mA
Average Operating Current	I _{CC2}	Cycle = Min, Duty = 100% I _{OUT} = 0mA	—	28 *(31)	60 *(75)	—	28 *(31)	60 *(75)	mA
Standby Current	I _{SB1}	$\overline{CE} \geq V_{CC} - 0.2V$	—	—	1.0	—	—	0.05	mA
	I _{SB2}	$\overline{CE} = V_{IH}$	—	—	2	—	—	1	mA
Output High Voltage	V _{OH}	I _{OH} = -1.0mA	2.4	—	—	2.4	—	—	V
Output Low Voltage	V _{OL}	I _{OL} = 4.0mA	—	—	0.4	—	—	0.4	V

Note) * Shows CXK5816PN/M-10, 10L value.

Capacitance

(Ta=25°C, f=1 MHz)

Item	Test condition	Symbol	Min.	Max.	Unit
Input Capacitance	V _{IN} =0V	C _{IN}	—	7	pF
Input/Output Capacitance	V _{I/O} =0V	C _{I/O}	—	10	pF

Note) This parameter is sampled and is not 100% tested.

AC Operating Characteristics

• AC Test condition

(V_{CC} = 5V ± 10%, Ta = 0 to +70°C)

Item	Condition
Input Pulse High Level	V _{IH} = 2.4V
Input Pulse Low Level	V _{IL} = 0.6V
Input Rise Time	t _R = 5ns
Input Fall Time	t _F = 5ns
Input and Output Timing Reference Level	1.5V
Output Load	Cl.* = 100pF, 1TTL

* Cl. includes scope and jig capacitance.

Read Cycle

Item	Symbol	CXK5816PN/M -10/10L		CXK5816PN/M -12/12L		CXK5816PN/M -15/15L		Unit
		Min.	Max.	Min.	Max.	Min.	Max.	
Read Cycle Time	t _{RC}	100	—	120	—	150	—	ns
Address Access Time	t _{AA}	—	100	—	120	—	150	ns
Chip Enable Access Time (CĒ)	t _{CO}	—	100	—	120	—	150	ns
Output Enable to Output Valid	t _{OE}	—	50	—	55	—	60	ns
Output Hold from Address Change	t _{OH}	15	—	15	—	15	—	ns
Chip Enable to Output in Low Z (CĒ)	t _{LZ}	15	—	15	—	15	—	ns
Output Enable to Output in Low Z (OĒ)	t _{OLZ}	10	—	10	—	10	—	ns
Chip Disable to Output in High Z	*t _{HZ}	0	30	0	40	0	50	ns
Output Disable to Output in High Z (OĒ)	*t _{OHZ}	0	30	0	40	0	50	ns

* t_{HZ} and t_{OHZ} are specified by the time length when the output circuit becomes closed and not specified by the output voltage level.

Write Cycle

Item	Symbol	CXK5816PN/M -10/10L		CXK5816PN/M -12/12L		CXK5816PN/M -15/15L		Unit
		Min.	Max.	Min.	Max.	Min.	Max.	
Write Cycle Time	t _{WC}	100	—	120	—	150	—	ns
Address Valid to End of Write	t _{AW}	80	—	100	—	120	—	ns
Chip Enable to End of Write	t _{CW}	80	—	100	—	120	—	ns
Data to Write Time Overlap	t _{DW}	30	—	35	—	40	—	ns
Data Hold from Write Time	t _{DH}	0	—	0	—	0	—	ns
Write Pulse Width	t _{WP}	60	—	75	—	90	—	ns
Address Setup Time	t _{AS}	0	—	0	—	0	—	ns
Write Recovery Time	t _{WR}	5	—	5	—	5	—	ns
Output Active from End of Write	t _{OW}	15	—	15	—	15	—	ns
Write to Output in High Z	t _{WHZ}	0	30	0	40	0	50	ns

Timing Waveform

(1) Read Cycle [$\overline{WE}=V_{IH}$]

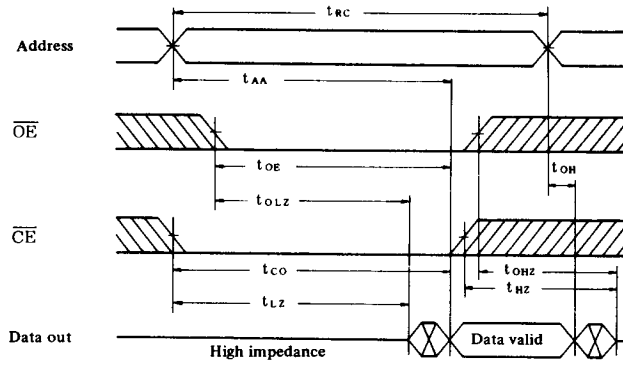

(2) Write Cycle

- Write Cycle No. 1: [$\overline{OE}=V_{IL}$ or V_{IH}] (*1)

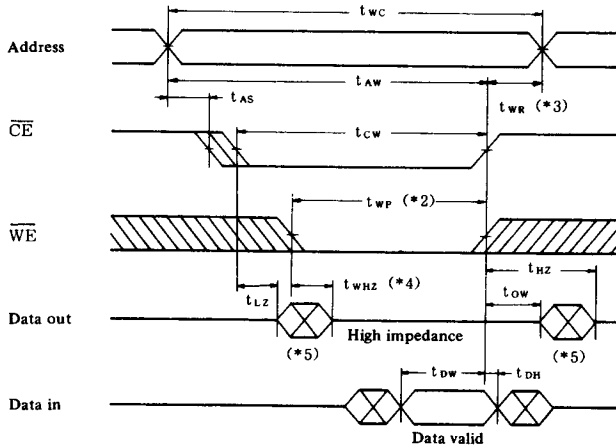

• Write Cycle No. 2: [$\overline{OE}=V_{IL}$ or V_{IH} , $\overline{CE}=V_{IL}$] (*1)

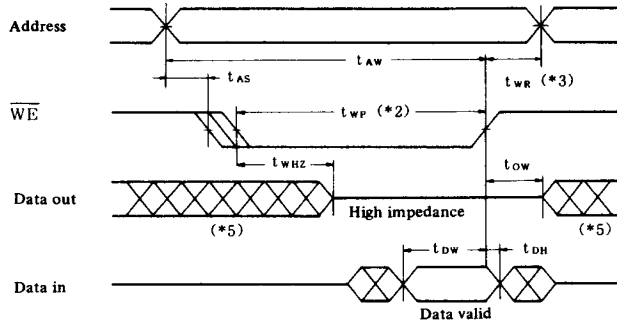

• Note)

1. If \overline{OE} is high, output remains in a high impedance state.
2. A write occurs during the low overlap of \overline{CE} and \overline{WE} .
3. t_{WR} is measured from the earlier of \overline{CE} or \overline{WE} going high to the end of write cycle.
4. If \overline{CE} low transition occurs simultaneously with the \overline{WE} low transition or after the \overline{WE} transition, output remains in a high impedance state.
5. During this period, I/O pins are in the output state so that the input signals of opposite phase to the outputs must not be applied.

Data Retention Characteristics

(Ta = 0 to +70 °C)

Item	Symbol	Test condition	CXK5816PN/M -10/12/15			CXK5816PN/M -10L/12L/15L			Unit
			Min.	Typ.	Max.	Min.	Typ.	Max.	
Data Retention Voltage	V _{DR}	$\overline{CE} \geq V_{CC} - 0.2V$	2.0	—	5.5	2.0	—	5.5	V
Data Retention Current	I _{CCDR1}	V _{CC} = 3.0V, $\overline{CE} \geq 2.8V$	—	—	600	—	—	30	μA
	I _{CCDR2}	V _{CC} = 2.0 to 5.5V, $\overline{CE} \geq V_{CC} - 0.2V$	—	—	1000	—	—	50	μA
Data Retention Set up Time	t _{CDRS}	Chip disable to data retention mode	0	—	—	0	—	—	ns
Recovery Time	t _R		t _{RC} *	—	—	t _{RC} *	—	—	ns

* t_{RC} : Read Cycle Time

Data Retention Waveform

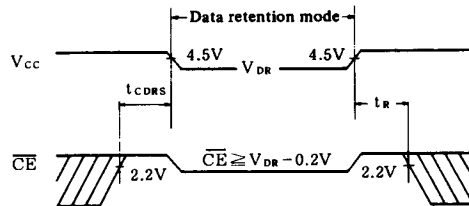

Supply Current vs. Supply Voltage

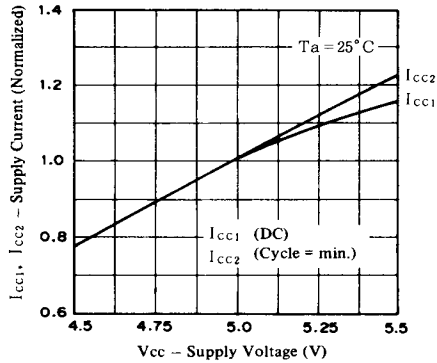

Supply Current vs. Ambient Temperature

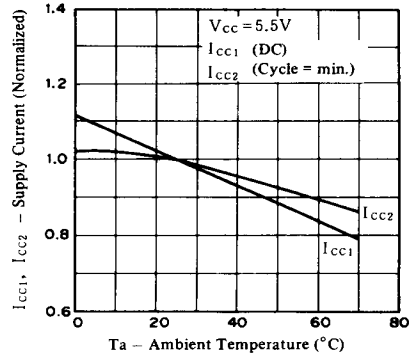

Supply Current vs. Frequency

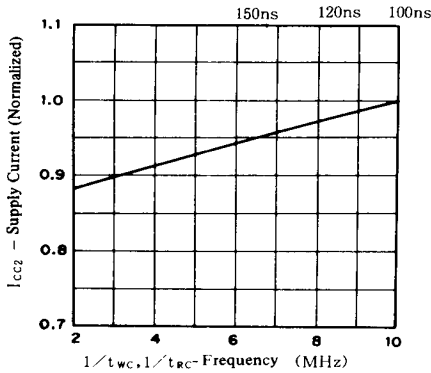

Access Time vs. Load Capacitance

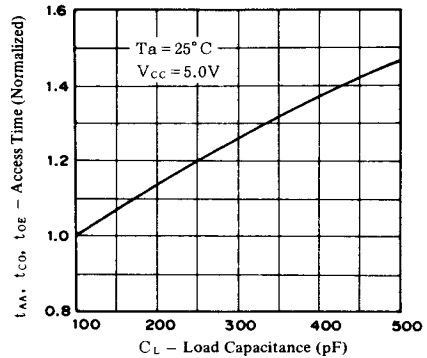

Access Time vs. Supply Voltage

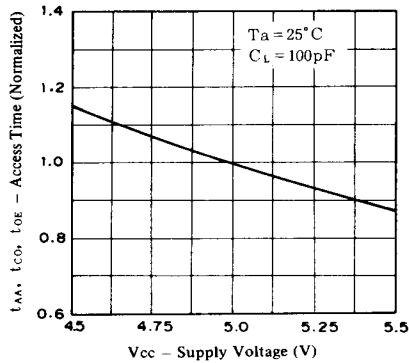

Access Time vs. Ambient Temperature

